



DETAIL AND SUBMITTAL SHEET

SAMSON PRODUCTS
INCORPORATED
JL INDUSTRIES
INCORPORATED

6285 Randolph Street
Commerce, CA 90040
Phone: 323-726-9070
FAX: 323-726-9068

DISTRIBUTOR: _____ CONTRACTOR: _____

MODEL NUMBER: _____ PROJECT: _____

QUANTITY: _____ APPROVED BY: _____

ARCHITECT: _____ DATE: _____

JL MID-WEST WAREHOUSE 4450 W. 78TH STREET CIRCLE BLOOMINGTON, MN 55435 PHONE: 952-835-6850 FAX: 952-835-2218
JL EAST COAST 316 B WILLOW ROAD, LANCASTER, PA 17601 PHONE: 1-800-554-6077
THOMAS ENTERPRISES 5758 CORPORATION CIRCLE, FORT MEYERS, FL 33905 PHONE: 941-693-7500 FAX: 941-693-7501

FIRE EXTINGUISHER HOSE AND VALVE CABINETS - FX OPTION

CROWNLINE - FX OPTION

Samson's Crowline series provide recessed and semi-recessed cabinets in three trim and door materials: steel, aluminum and stainless steel respectively. Ideal for schools, hospitals, hotels, motels, apartments, supermarkets, etc. These cabinets come with a great variety of combination metal-glass door styles and sizes to suit most all portable fire extinguishers, valve and hose racks.

Crowline cabinets come standard with a continuous hinge. These flush cabinet doors consist of a formed design with 5/8" nominal thickness. The doorstop therefore extends 5/8" into the tub. The standard door hardware for non-break glass doors consists of zinc plated pull handles and roller catch. A cylinder lock with flexible cam and pull handle is standard for SAF-T-LOK. All cabinets feature a 1 3/4" face width on the trim and door. All semi-recessed cabinets with a 2 1/2" RT have trims with a rolled edge construction. The surface mount stainless steel trims also have rolled edge construction. All other trim configurations are square edged.

Knock-outs are not provided on FIRE-FX™ cabinets. Instructions for the knockouts in the fields are provided and must be strictly adhered to maintain fire-rating.

Model VE-1 features a shelf 12" from the bottom of the tub. The area below the shelf houses a 2 1/2" angle valve. Area above the shelf houses fire extinguisher. This model is also available without shelf when specified.

FIRE-FX™ OPTION

FIRE RATED EXTINGUISHER HOSE AND VALVE CABINETS

Samson features fire-rated extinguisher and hose and valve cabinets for use in fire-rated walls. Samson's specially designed and patented FIRE-FX™ Option for 1-hour and 2-hour combustible and non-combustible wall systems.

To determine wall opening and wall depth needed, consult series dimension tables.

FIRE-FX™ OPTION ELIMINATES:

- The costly need to line the wall opening cavity with fire rated material.
- Guess work as to whether the fire barrier has been compromised by the above procedure.

Cabinet to be fabricated in accordance with UBC 7-5 (ASTM E814-97) & UBC 7-1 (ASTM E119-97) under positive pressure to measure fire resistive performance.

FIRE RATED TOP VIEW

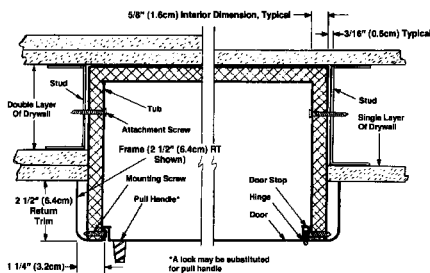

1. AVAILABLE DOOR STYLES (SELECT ONE)

- F FULL GLASS
- G FULL WITH SAF-T-LOK GLASS
- D DUO PANEL
- E TOP DUO PANEL WITH SAF-T-LOK
- A CENTER DUO PANEL WITH SAF-T-LOK
- S21 SOLID
- L22 SOLID WITH LOCK
- B SOLID WITH GLASS INSERT AND SAF-T-LOK
- V CONTEMPORARY V
- W CONTEMPORARY V WITH SAF-T-LOK

2. AVAILABLE DOOR GLAZING (SELECT ONE)

- 10 DS (DOUBLE STRENGTH) GLASS
- 11 PLATE GLASS
- 12 1/4" CLEAR ACRYLIC
- 13 CLEAR WIRE GLASS
- 15 BRONZE GLASS
- 16 GRAY GLASS
- 17 CLEAR TEMP. GLASS
- 18 LAMINATED SAFETY GLASS
- 20 SS (SINGLE STRENGTH) GLASS
- 30 .060 CLEAR ACRYLIC

3. OPTIONS (SELECT ANY)

- BREAK GLASS HAMMER AND CHAIN
- COLOR ANODIZED DOOR AND TRIM; ACADEMY
- COLOR EPOXY TUB (RED OR BLACK)
- COLOR EPOXY DOOR AND TRIM (RED OR BLACK); AMBASSADOR
- FE LETTERS IN BLACK, RED OR WHITE
- FUTURA "FIRE" HANDLE
- STAINLESS DOOR AND TRIM, #32 POLISHED FINISH, COSMOPOLITAN

EXPLODED TOP AND SIDE VIEWS REFER TO DIMENSIONS TABLE

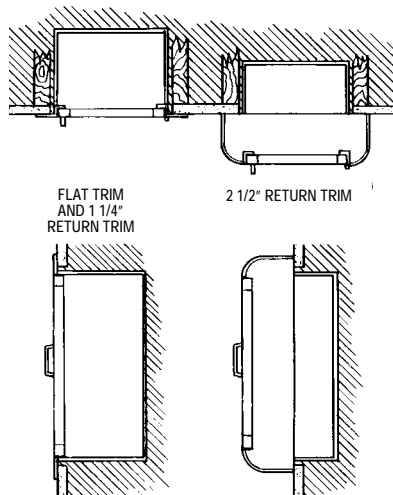
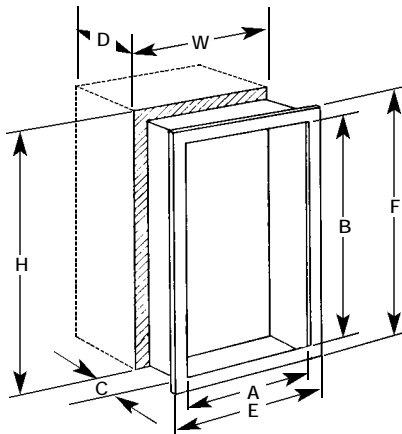

HOSE VALVE CABINET DIMENSIONS - FX OPTION

DIMENSIONS IN INCHES

TRIM & DOOR MAT. & SERIES #			TRIM STYLE	TUB I.D.			FRAME O.D.		WALL OPENING <small>FX OPTION</small>			RECOMMENDED HOSE RACK EXTINGUISHERS
STEEL	ALUM.	STAINLESS STEEL		A	B	C	E	F	W	H	D	
-	-	-	-	-	-	-	-	-	-	-	-	Cosmic 5, 6, 10 1-1/2" hose rack unit 100 ft hose (172 F-1-100NST)
___6015	___6025	___6035	FLAT TRIM	24"	30"	6"	27 3/8"	33 3/8"	26"	32 1/8"	6 5/8"	
___6016	___6026	___6036	1 1/4"	24"	30"	6"	27 3/8"	33 3/8"	26"	32 1/8"	5 3/4"	
___6017	___6027	___6037	2 1/2"	24"	30"	6"	27 3/8"	33 3/8"	26"	32 1/8"	4 1/2"	
-	-	-	-	-	-	-	-	-	-	-	-	Cosmic 5, 6, 10 1-1/2" hose rack unit 100 ft hose (172 F-1-100NST)
___6215	___6225	___6235	FLAT TRIM	24"	34 3/4"	6"	27 3/8"	38 1/8"	26"	36 7/8"	6 5/8"	
___6216	___6226	___6236	1 1/4"	24"	34 3/4"	6"	27 3/8"	38 1/8"	26"	36 7/8"	5 3/4"	
___6217	___6227	___6237	2 1/2"	24"	34 3/4"	6"	27 3/8"	38 1/8"	26"	36 7/8"	4 1/2"	
-	-	-	-	-	-	-	-	-	-	-	-	2-1/2" x 1-1/2" hose rack unit 100 ft hose (172 F-1-100NST)
___6115	___6125	___6135	FLAT TRIM	24"	30"	8"	27 3/8"	33 3/8"	26"	32 1/8"	8 5/8"	
___6116	___6126	___6136	1 1/4"	24"	30"	8"	27 3/8"	33 3/8"	26"	32 1/8"	7 3/4"	
___6117	___6127	___6137	2 1/2"	24"	30"	8"	27 3/8"	33 3/8"	26"	32 1/8"	*6 1/2"	
-	-	-	-	-	-	-	-	-	-	-	-	2-1/2" x 1-1/2" hose rack unit 100 ft hose (172 F-1-100NST)
___6415	___6425	___6435	FLAT TRIM	24"	34 3/4"	8"	27 3/8"	38 1/8"	26"	36 7/8"	8 5/8"	
___6416	___6426	___6436	1 1/4"	24"	34 3/4"	8"	27 3/8"	38 1/8"	26"	36 7/8"	7 3/4"	
___6417	___6427	___6437	2 1/2"	24"	34 3/4"	8"	27 3/8"	38 1/8"	26"	36 7/8"	*6 1/2"	
-	-	-	-	-	-	-	-	-	-	-	-	2-1/2" x 1-1/2" hose rack unit 100 ft hose (172 F-1-100NST) 2 1/2" fire dept. valve
___6615	___6625	___6635	FLAT TRIM	24"	38 3/4"	8"	27 3/8"	42 1/8"	26"	40 7/8"	8 5/8"	
___6616	___6626	___6636	1 1/4"	24"	38 3/4"	8"	27 3/8"	42 1/8"	26"	40 7/8"	7 3/4"	
___6617	___6627	___6637	2 1/2"	24"	38 3/4"	8"	27 3/8"	42 1/8"	26"	40 7/8"	*6 1/2"	
-	-	-	-	-	-	-	-	-	-	-	-	1 1/2" hose rack unit with hose with maximum size extinguishers 20 lb cosmic 10 sentinel
___6315	___6325	___6335	FLAT TRIM	30"	30"	8"	33 3/8"	33 3/8"	32"	32 1/8"	8 5/8"	
___6316	___6326	___6336	1 1/4"	30"	30"	8"	33 3/8"	33 3/8"	32"	32 1/8"	7 3/4"	
___6317	___6327	___6337	2 1/2"	30"	30"	8"	33 3/8"	33 3/8"	32"	32 1/8"	*6 1/2"	
-	-	-	-	-	-	-	-	-	-	-	-	1 1/2" or 2 1/2" hose rack unit with hose with maximum size ext. 2 1/2 gal. 20 lb cosmic 10 sentinel
___6515	___6525	___6535	FLAT TRIM	32 3/4"	34 3/4"	8"	36 1/8"	38 1/8"	35"	36 7/8"	8 5/8"	
___6516	___6526	___6536	1 1/4"	32 3/4"	34 3/4"	8"	36 1/8"	38 1/8"	35"	36 7/8"	7 3/4"	
___6517	___6527	___6537	2 1/2"	32 3/4"	34 3/4"	8"	36 1/8"	38 1/8"	35"	36 7/8"	*6 1/2"	
-	-	-	-	-	-	-	-	-	-	-	-	1 1/2" or 2 1/2" x 1 1/2" hose rack unit with hose with max. size ext. 2 1/2 gal. 20 lb cosmic 10 sentinel
___7215	___7225	___7235	FLAT TRIM	32 3/4"	38 3/4"	8"	36 1/8"	42 1/8"	35"	40 7/8"	8 5/8"	
___7216	___7226	___7236	1 1/4"	32 3/4"	38 3/4"	8"	36 1/8"	42 1/8"	35"	40 7/8"	7 3/4"	
___7217	___7227	___7237	2 1/2"	32 3/4"	38 3/4"	8"	36 1/8"	42 1/8"	35"	40 7/8"	*6 1/2"	
-	-	-	-	-	-	-	-	-	-	-	-	2 1/2" fire department valve
___8515	___8525	___8535	FLAT TRIM	18"	18"	8"	21 3/8"	21 3/8"	20"	20 1/8"	8 5/8"	
___8516	___8526	___8536	1 1/4"	18"	18"	8"	21 3/8"	21 3/8"	20"	20 1/8"	7 3/4"	
___8517	___8527	___8537	2 1/2"	18"	18"	8"	21 3/8"	21 3/8"	20"	20 1/8"	*6 1/2"	
-	-	-	-	-	-	-	-	-	-	-	-	2 1/2" fire department valve
___8715	___8725	___8735	FLAT TRIM	26"	26"	8"	29 3/8"	29 3/8"	28"	28 1/8"	8 5/8"	
___8716	___8726	___8736	1 1/4"	26"	26"	8"	29 3/8"	29 3/8"	28"	28 1/8"	7 3/4"	
___8717	___8727	___8737	2 1/2"	26"	26"	8"	29 3/8"	29 3/8"	28"	28 1/8"	*6 1/2"	
-	-	-	-	-	-	-	-	-	-	-	-	2 1/2" fire department valve and 2 1/2 gal. 20 lb cosmic 10 sentinel
___8015	___8025	___8035	FLAT TRIM	16"	40"	9"	19 3/8"	43 3/8"	18"	42 1/8"	10"	
___8016	___8026	___8036	1 1/4"	16"	40"	9"	19 3/8"	43 3/8"	18"	42 1/8"	9 1/8"	
___8017	___8027	___8037	2 1/2"	16"	40"	9"	19 3/8"	43 3/8"	18"	42 1/8"	*7 1/2"	
-	-	-	-	-	-	-	-	-	-	-	-	2 1/2" fire department valve
___8415	___8425	___8435	FLAT TRIM	18"	18"	10"	21 3/8"	21 3/8"	20"	20 1/8"	10 5/8"	
___8416	___8426	___8436	1 1/4"	18"	18"	10"	21 3/8"	21 3/8"	20"	20 1/8"	9 3/4"	
___8417	___8427	___8437	2 1/2"	18"	18"	10"	21 3/8"	21 3/8"	20"	20 1/8"	8 1/2"	
-	-	-	-	-	-	-	-	-	-	-	-	2 1/2" fire department valve
___8615	___8625	___8635	FLAT TRIM	26"	26"	10"	29 3/8"	29 3/8"	28"	28 1/8"	10 5/8"	
___8616	___8626	___8636	1 1/4"	26"	26"	10"	29 3/8"	29 3/8"	28"	28 1/8"	9 3/4"	
___8617	___8627	___8637	2 1/2"	26"	26"	10"	29 3/8"	29 3/8"	28"	28 1/8"	8 1/2"	

*ADD 5/8" FOR CABINETS WITH ALUMINUM FRAMES
9" TUB OPTION AVAILABLE ON SERIES 6100, 6400, 6600, 6300, 6500, AND 7200 FOR ALL TRIM STYLES, CONSULT FACTORY.